

# *Eclipse BoostPak*

---

## *Packaged Gas Booster System*

Model LS  
Version 2

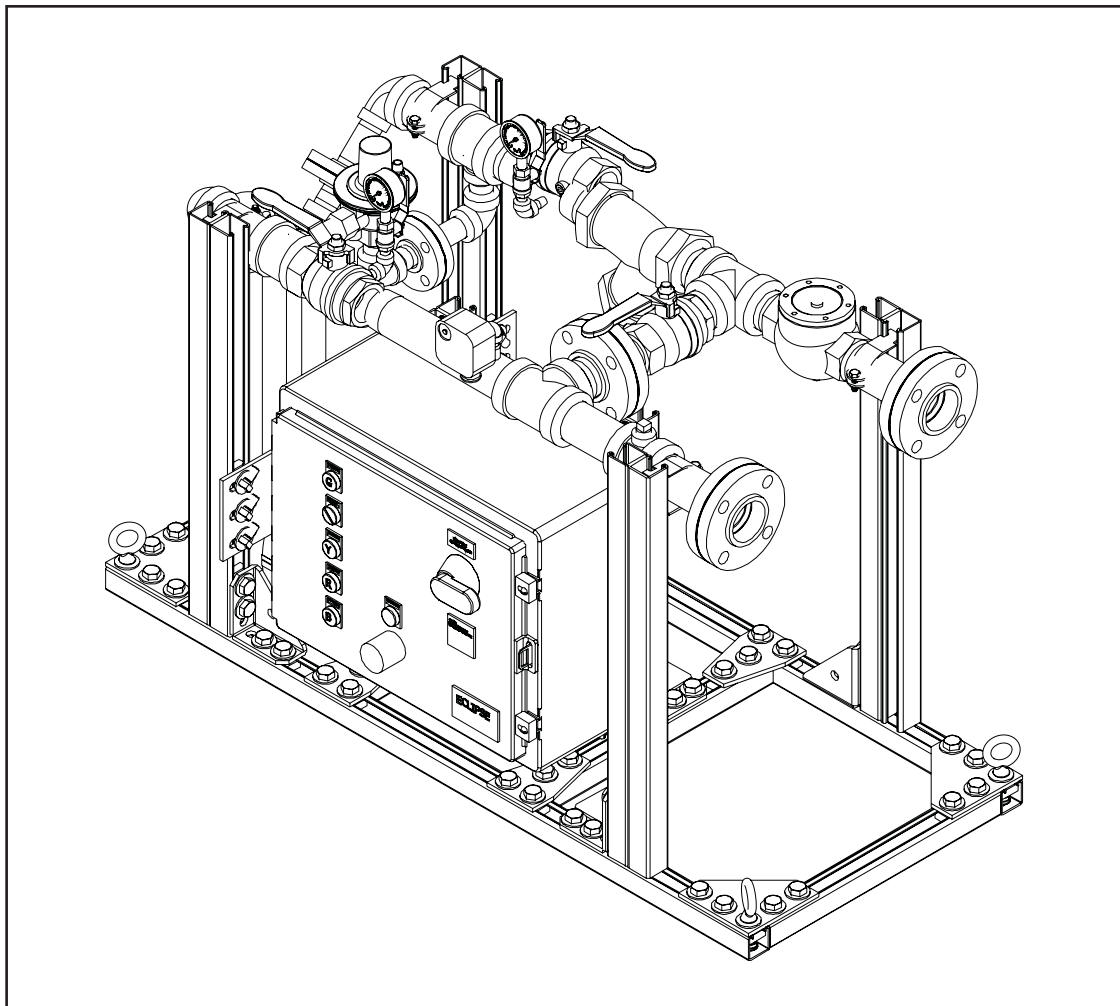

## **COPYRIGHT**

Copyright 2007 by Eclipse, Inc. All rights reserved worldwide. This publication is protected by federal regulation and shall not be copied, distributed, transmitted, transcribed or translated into any human or computer language, in any form or by any means, to any third parties, without the express written consent of Eclipse, Inc.

## **DISCLAIMER NOTICE**

In accordance with the manufacture's policy of continual product improvement, the product presented in this brochure is subject to change without notice or obligation.

The material in this manual is believed adequate for the intended use of the product. If the product is used for purposes other than those specified herein, confirmation of validity and suitability must be obtained. Eclipse warrants that the product itself does not infringe upon any United States patents. No further warranty is expressed or implied.

## **LIABILITY AND WARRANTY**

We have made every effort to make this manual as accurate and complete as possible. Should you find errors or omissions, please bring them to our attention so that we may correct them. In this way we hope to improve our product documentation for the benefit of our customers. Please send your corrections and comments to our Marketing Communications Manager.

It must be understood that Eclipse's liability for its product, whether due to breach of warranty, negligence, strict liability, or otherwise is limited to the furnishing of replacement parts and Eclipse will not be liable for any other injury, loss, damage or expenses, whether direct or consequential, including but not limited to loss of use, income, or damage to material arising in connection with the sale, installation, use of, inability to use, or the repair or replacement of Eclipse's products.

Any operation expressly prohibited in this Guide, any adjustment, or assembly procedures not recommended or authorized in these instructions shall void the warranty.



# *About this manual*

## **AUDIENCE**

This manual has been written for people who are already familiar with all aspects of gas booster systems and its add-on components.

These aspects are:

- Installation
- Use
- Maintenance

The audience is expected to have previous experience with this type of equipment.

## **BOOSTPAK DOCUMENTS**

### **Installation Guide No. 630-I**

This document

### **Data Sheet No. 630-I**

- Available for BoostPak models LS
- Provides assembly drawing numbers
- Required to complete installation

### **System Drawings**

- 10024840 (LS1010)
- 10024841 (LS 1515)
- 10024842 (LS2020)
- 10025020 (Control Panel)

### **Price List No. 630**

- Used to order BoostPak

### **Related Documents**

- EFE 825 (Combustion Engineering Guide)
- Eclipse bulletins and Info Guides: 620, 710, 780, 940

### **Purpose**

The purpose of this manual is to make sure that you carry out the installation of a safe, effective, and trouble-free system.

## DOCUMENT CONVENTIONS

There are several special symbols in this document. You must know their meaning and importance.

The explanation of these symbols follows below. Please read it thoroughly.



### **Danger:**

**Indicates hazards or unsafe practices which WILL result in severe personal injury or even death.**

**Only qualified and well trained personnel are allowed to carry out these instructions or procedures.**

**Act with great care and follow the instructions.**



### **Warning:**

**Indicates hazards or unsafe practices which could result in severe personal injury or damage.**

**Act with great care and follow the instructions.**



### **Caution:**

*Indicates hazards or unsafe practices which could result in damage to the machine or minor personal injury, act carefully.*



### **Note:**

*Indicates an important part of the text. Read thoroughly.*

## HOW TO GET HELP

If you need help, contact your local Eclipse representative.



# Table of Contents

<b>1</b>	<b>Introduction</b> .....	<b>6</b>
	Product Description.....	6
<b>2</b>	<b>Safety</b> .....	<b>7</b>
	Introduction .....	7
	Safety.....	7
	Capabilities .....	7
	Operator Training.....	7
	Replacement Parts.....	7
<b>3</b>	<b>Installation</b> .....	<b>8</b>
	Introduction .....	8
	Handling and Storage .....	8
	Checklist Before Installation.....	8
	Mechanical Installation .....	9
	Piping Installation.....	9
	Electrical Installation.....	11
	Checklist After Installation.....	12
<b>4</b>	<b>Commissioning</b> .....	<b>13</b>
	Introduction .....	13
	Setting the Regulator .....	14
	Operational Tests .....	14
	Commissioning Record .....	15
<b>5</b>	<b>Operation</b> .....	<b>16</b>
	Introduction .....	16
	Alarm Silence .....	16
	Shutdown.....	17
<b>6</b>	<b>Maintenance &amp; Troubleshooting</b> .....	<b>18</b>
	Monthly Checklist.....	18
	Annual Checklist .....	18
	Troubleshooting Guide.....	18
	Wiring Diagram.....	20
	Mechanical Drawing.....	22
	Piping Schematic.....	22
	Panel Layout .....	23
	Spare Parts List.....	24
	Key To System Drawings .....	25
	<b>Appendix</b> .....	<b>26</b>
	Conversion Factors .....	26

# Introduction

1

## PRODUCT DESCRIPTION

The Eclipse BoostPak is designed for installations when the gas pressure to a building is inadequate to operate the appliances. It provides a reliable cost-effective packaged solution for pumping low natural gas supply pressures up to meet the requirements of high performance combustion equipment. The discharge pressure is the total of the booster added pressure plus the incoming gas pressure.

The BoostPak is a completely integrated skid mounted package. It is factory assembled, wired, tested, and ready for field power and gas connections. The system includes but is not limited to a gas booster blower, check valve, gas pressure switch, isolating valves, inlet and outlet piping and flange connectors, pressure gauges, and control system all mounted, assembled, wired, and tested. All essential components for automatic operation are enclosed in an industrial control panel designed to meet local and national electrical codes.

Various standard options may be selected to configure a complete model number. The options determine the control modes, pressure boost, flow, and environmental conditions.

**The Eclipse BoostPak**

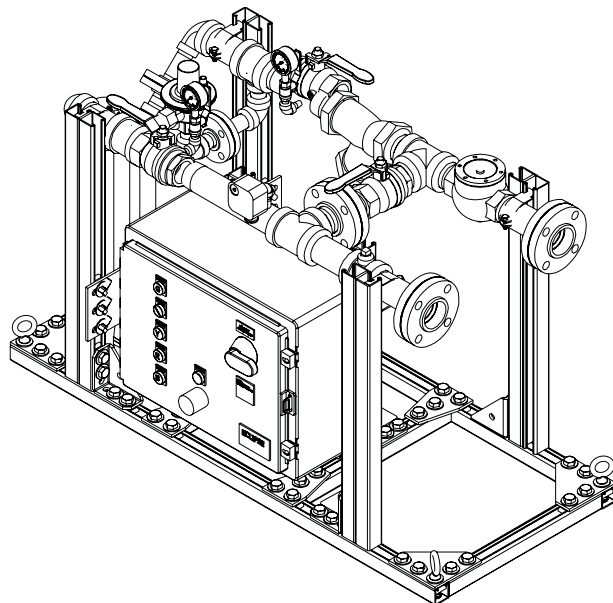

# Safety

# 2

## INTRODUCTION

## SAFETY

## CAPABILITIES

## OPERATOR TRAINING

## REPLACEMENT PARTS

This section is provided as a guide for the safe operation of the BoostPak system. All involved personnel should read this section carefully before operating this system.



### **Danger:**

**The BoostPak packaged gas booster system, described herein, is designed to increase gas pressure to a gas utilization appliance. All fuel handling devices are capable of producing fires and explosions if improperly applied, installed, adjusted, controlled, or maintained. Do not bypass any safety feature; fire or explosion could result.**

**Never try to operate a BoostPak if it shows signs of damage or malfunction.**



### *Note:*

*This manual provides information in the use of the BoostPak for its specific design purpose. Do not deviate from any instructions or application limits described herein without written advice from Eclipse.*

*Read the entire manual before attempting to start this system. If you do not understand any part of the information contained in this manual, contact your local Eclipse representative or Eclipse, Inc. before continuing.*

Only qualified personnel, with good mechanical aptitude and experience with combustion equipment, should adjust, maintain, or troubleshoot any mechanical or electrical part of this system.

The best safety precaution is an alert and trained operator. Train new operators thoroughly and have them demonstrate an adequate understanding of the equipment and its operation. A regular retraining schedule should be administered to ensure operators maintain a high degree of proficiency.

Order replacement parts from Eclipse only. Refer to the system drawings and illustrated parts list in this guide.

# Installation

# 3

## INTRODUCTION

## HANDLING AND STORAGE

## CHECKLIST BEFORE INSTALLATION

In this chapter you will find information and instructions needed to install the BoostPak and system components. The following system drawings are shipped with the equipment: for LS1010, dwg. 10024840; for LS1515, dwg. 10024841; for LS 2020, dwg. 10024842; and for the control panel, dwg. 10025020.

### Handling

- Inspect the system, being sure the components are clean and free of damage.
- Use the appropriate support and handling equipment when lifting the BoostPak.
- Protect all components on the system from weather, damage, dirt and moisture.
- Protect the system and its components from excessive temperatures and humidity.

### Storage

- When storing the system for an extended period Eclipse recommends placing it in a cool, clean, dry room.
- Keep all the system components stored in their original packaging as long as possible.

### Placement

The Eclipse BoostPak is completely factory piped, wired with controls, tested and ready for field connections. The system should be installed in an accessible ventilated location on a level concrete floor or substantial mounting pad. Place the BoostPak to avoid excessive numbers of bends and fittings in the interconnecting piping. Avoid locations subject to falling dirt and debris, or provide a guard to prevent objects from falling and lodging into the cooling fan of the booster motor.

### Access

The BoostPak location must allow easy accessibility for inspection and maintenance. Provide adequate space all around the BoostPak in order to facilitate servicing and field replacement of components. Avoid obstructing the open access to the control panel.



## CHECKLIST BEFORE INSTALLATION (CONTINUED)

## MECHANICAL INSTALLATION

## PIPING INSTALLATION



Note:

There should be no less than 36" of clearance from the front of the control panel door and the swing of the door should not be obstructed from opening 120°. If local codes are different than these requirements, those codes should be adhered to during installation.

### Environment

Be sure the operating environment matches the original operating specifications. Check the following items:

- Voltage, frequency, and stability of electrical power
- Ambient temperature and humidity
- Area classification (non-hazardous or hazardous)
- Exposure to sunlight, water, ice, wind, and vibration

### Lift Points

Use lifting lugs on mounting base for all lifting. Do not use piping or supports as lift points unless designated by manufacturer labeling.

### Mounting

The customer is to drill clearance holes in the unistrut base and secure it to a foundation.

### Gas Piping

All gas piping must be done in accordance with the national fuel gas code, the local utility company and municipal agency requirements. Protect and prevent contamination of the piping during installation.



Note:

If it is necessary to redirect piping, make sure all devices are properly oriented with respect to flow direction and vertical (gravity) orientations.



Note:

Avoid severe size reductions in pipe connections, unnecessary fittings, and excessive numerous bends that may cause additional flow restriction and pressure loss. Elbows within 5 pipe diameters may reduce pressure and capacity below operating requirements.

### Piping Support

Use brackets or hangers to support the gas piping. If you have questions, consult your local gas company.

### Initial Fitting

- Remove any packing and shipping materials and inspect for foreign objects in the piping.
- Connect inlet gas piping from the utility supply to the inlet flange as indicated by directional arrows and on the system drawings.
- Connect the gas pipe feeding your appliance that requires the boosted gas pressure to the discharge gas pipe outlet flange, also indicated by label and the system drawing.

## PIPING INSTALLATION (CONTINUED)

### Vent Piping

The model LS BoostPak does not require vent piping. Vent piping may be required for components added to the system. Check the individual product data sheets for specific manufacturer's recommendations.

### Inlet Low Gas Manual Reset Pressure Switch

This switch may come already mounted and wired on the BoostPak, or it may be supplied as a kit to be remotely mounted. Install loose inlet gas low pressure switch kit in location determined by the utility company. Normally it is located downstream of the main regulator just inside the building where the supply pipe enters.

### Inlet High Gas Pressure Switch

If used, this optional switch may come already mounted and wired on the BoostPak, or it may be supplied as a kit to be remotely mounted. Install loose inlet gas high pressure switch kit in location determined by the specifying engineer. Normally it is located downstream of the main regulator just inside the building where the supply pipe enters.

### Pressure Switch Settings

- Check and adjust the pressure switches as required.
- The utility company dictates the setting of the low inlet gas pressure switch typically at 3-4"wc to prevent operation when there is insufficient gas volume.
- The discharge gas pressure switch should be set 2-4"wc below the rated discharge pressure at the maximum flow conditions for the site application.
- If installed, the optional inlet high gas pressure switch should be set to 90% of the pressure where the sum of the inlet plus the rated boost equals the maximum rating of downstream equipment. Alternately it can be set to 20% above the minimum requirement of the downstream equipment.

### Leak Testing

The BoostPak is tested and leak tight at the factory, however shipping and installation may cause joints to loosen. Check and test all piping for leaks.



#### **Warning:**

**Test pressure must not exceed 3 PSIG and the pressure gauges or any components with ratings less than the test pressure should first be isolated. Check the individual product data sheets for specific ratings.**

# ELECTRICAL INSTALLATION

## General

All electrical wiring must be done in accordance with the national electrical code, the local utility company and municipal agency requirements. The schematics are shipped with the BoostPak. Contact Eclipse for replacement, drawing 10025020.

The BoostPak is pre-wired and therefore only the electrical power supply and any externally supplied control devices must be terminated. Depending on the specific model configuration, the external devices can include the appliance run interlock contact and the low inlet gas pressure switch.

## Review Nameplate

Before making any electrical connections, compare the electrical supply circuit ratings at the installation site to those on the nameplates of the BoostPak, control panel, and booster motor. The supply for the BoostPak model LS must be 120VAC nominal and must be capable of supplying the booster motor full load current of 2 amps and starting current of 7 amps.

## Terminal Check

During shipment, the control panel terminals may have loosened. Check the tightness of all connections in the panel and at the pressure switches.

## Supply Power Wiring

The incoming power to the control panel must be wired into the terminals as designated in the schematic diagram. Earth ground must be connected to terminal G.

## Wiring for Continuous Operation

This control mode allows an operator to turn a local control panel switch on when pressure boost is needed and turn the switch off when the boost is not needed. For this mode, a jumper is installed between terminals I32I and 2I6I.

## Wiring for Appliance On Demand Operation, Start Circuit Interlock

This control mode requires a customer supplied run interlock. It must be a dry (voltage free) contact that makes continuity when the booster is required and opens when the booster should shut down. Commonly used devices include:

- An automatic time clock
- flow switch
- relay contact
- switch contact

For this mode, wire the contact between terminals I32I and 2I6I. Be sure to remove any jumper connection between these terminals if present.

## Wiring for Flow Sensor Demand Control Operation

This control mode is an option that is typically ordered and installed at the factory. If it has been supplied as a kit, refer to Data 630-FC and Installation Guide 630-FC.

## ELECTRICAL INSTALLATION (CONTINUED)

## CHECKLIST AFTER INSTALLATION

### Wiring for Inlet Low Gas Manual Reset Pressure Switch

This switch may come already mounted and wired on the BoostPak, or it may be supplied as a kit to be remotely mounted. This switch is required by the local utility company as a safety device. The kit version must be wired into the BoostPak control panel. Wire the low inlet gas pressure switch terminal 3 (COM) to panel terminal 1321, and switch terminal 2 (NO) to panel terminal 2121. Be sure to remove any jumper connection between these terminals if present.

### Wiring for Inlet High Gas Pressure Switch

If installed, this optional switch may come already mounted and wired on the BoostPak, or it may be supplied as a kit to be remotely mounted. The kit version must be wired into the BoostPak control panel. Wire the high inlet gas pressure switch terminal 3 (COM) to panel terminal 2161, and switch terminal 1 (NC) to panel terminal 2162. Be sure to remove the jumper wire between these terminals if present.

### Alarm Output Wiring

A terminal is provided to connect an external alarm. If used, wire the external alarm to panel terminal 2331 (hot) and 1323 (neutral). The external alarm should be rated for 120VAC and not exceed 2 amps.

### Ensure the system was properly installed and verify:

- The skid is securely bolted to the floor or mounting pad and is rigid and level.
- There are no loosely mounted components.
- There are no leaks in the gas lines.
- The external gas piping has appropriate brackets and is not supported by the BoostPak.
- Verify correct orientation of gas piping – from utility point of entry to BoostPak inlet, from BoostPak outlet to the appliance.
- Verify sufficient unobstructed access to the control panel and booster motor.
- Verify electrical power supply and all external devices are wired correctly.
- Verify tightness of all terminal connections on all devices.
- Verify the gas pressure switch(es) are installed in the correct location and confirm the proper settings.
- Verify all device orientations are correct with respect to flow direction.
- Check for and clean out debris on the cooling fan of the booster motor.
- Inspect and remove any metal debris that may have attached to the magnetic motor coupling on the booster.

# Commissioning

## 4

### INTRODUCTION

In this chapter you will find information and procedures for the first operation and adjustment of the BoostPak.



**Warning:**

**Only qualified personnel, with good mechanical and electrical aptitude should adjust, maintain, or troubleshoot any mechanical or electrical part of this system. They should have knowledge and experience with combustion equipment including piping, valves, motors, blowers, boosters, switches, control panels and wiring.**

These instructions rely on the expertise of the person performing the start up. If you do not understand any portion of this procedure or do not feel qualified, stop and call Eclipse.

Before applying the site electrical power supply to the BoostPak control panel:

- Turn off the main disconnect switch.
- Turn the MAN/OFF/AUTO control switch to OFF.

Turn the control panel main disconnect switch on and verify that the panel instrumentation has power. Momentarily turn the MAN/OFF/AUTO switch to MAN position to “bump” the motor starter such that the motor just starts to turn and rotates slowly. Observe the direction of rotation of the fan blades on the rear of the booster motor. They should be turning in a clockwise direction. If rotation direction is incorrect, have a qualified electrician rewire the incoming power for the proper direction.

Before applying the site gas supply initially set the manual ball valves:

- Open the bypass valve if supply is required downstream of the BoostPak
- Open the booster inlet valve
- Close the booster outlet valve

Turn on the gas supply to the BoostPak and press the reset on the Inlet Low Gas Manual Reset Pressure Switch.

## SETTING THE REGULATOR

If the regulator needs to be adjusted, carefully open the cap on top of the regulator stem and do not lose or damage its gasket.

- To decrease the BoostPak outlet pressure, screw the adjusting disc inside the stem counterclockwise. It will move outwards towards the top of the stem.
- To increase BoostPak outlet pressure, screw the adjusting disc clockwise. Do not adjust the disc close to the bottom of the stem; stop well before getting to the end of the threads.

Replace gasket and regulator cap. Then set the manual ball valves:

- Open the booster outlet valve.
- Be sure the inlet valve is still open.
- Close BoostPak bypass valve.

## OPERATIONAL TESTS

Test the operation of the BoostPak and verify:

- **DISCHARGE PRESSURE SWITCH:** The low gas light and alarm comes on with the outlet valve closed. The booster should remain running.
- **LOW INLET GAS PRESSURE SWITCH:** The booster stops, the low gas light and alarm comes on when the Inlet Low Gas Manual Reset Pressure Switch is adjusted above the inlet gas supply. Adjust this switch back to the original specified set point and observe that the system will not restart unless the pressure switch is first manually reset.
- **APPLIANCE RUN INTERLOCK:** For appliance on demand operation mode, turn the control switch to AUTO and test that the system runs when the appliance interlock makes.

1. Run system at nominal flow rating.
2. Verify pressure increase from booster is correct. Read the inlet and outlet pressure gauges on the BoostPak. Subtract the inlet from outlet pressure to verify added pressure agrees with the Data Sheet.
3. Verify that outlet pressure is sufficient for appliance operation.
4. Verify flow is sufficient for appliance via gas metering located at the appliance (not included with BoostPak).
5. Run system to minimum flow condition; verify flows and pressures within acceptable range.
6. Record all setup data as an aid for future troubleshooting and setup operations.

# COMMISSIONING RECORD FOR ECLIPSE BOOSTPAK MODEL LS

## Nameplate Information

BoostPak Model \_\_\_\_\_

Serial Number \_\_\_\_\_

Control Panel Serial Number \_\_\_\_\_

## Mechanical Instalation

Ambient Temperature \_\_\_\_\_

Mounting Secure, Rigid, Level \_\_\_\_\_

Supply and Feed Piping Supported \_\_\_\_\_

Leak Test--Do not exceed 3 PSI \_\_\_\_\_

Low Inlet Gas Pressure Switch Setting \_\_\_\_\_

High Inlet Gas Pressure Switch Setting \_\_\_\_\_

Outlet Gas Pressure Switch Setting \_\_\_\_\_

## Performance

Gas Inlet Pressure \_\_\_\_\_

BoostPak Outlet Pressure, Low Flow \_\_\_\_\_

BoostPak Outlet Pressure, High Flow \_\_\_\_\_

Power Supply Voltage \_\_\_\_\_

Booster Motor Current \_\_\_\_\_

I certify this equipment is installed per the requirements of the manufacturer and that it is performing to its specifications.

By: \_\_\_\_\_

Date: \_\_\_\_\_

# Operation

# 5

## INTRODUCTION

In this chapter, you will find instructions on how to start and stop the booster system. Become familiar with booster control methods before operating the equipment.



### **Danger:**

**The BoostPak system, described herein, is designed to increase gas pressure to an appliance. All fuel-handling devices are capable of producing fires and explosions if improperly applied, installed, adjusted, controlled, or maintained.**

**Do not bypass any safety feature; fire or explosion could result. Never try to operate a BoostPak if it shows signs of damage or malfunction.**

1. Be sure the inlet and outlet valves are open and bypass valve is closed. Turn the main disconnect switch on.
2. The green POWER ON light comes on
3. Check for ALARM conditions and correct before proceeding. See Alarm Conditions in the troubleshooting section of this guide.
4. Turn the control switch to AUTO.  
The BoostPak is in operation.
  - For Continuous Operation mode, the booster will run within 15 seconds of the switch operation.
  - For Appliance On Demand mode, the booster will run within 15 seconds of the closure of the appliance run interlock contact.

The booster motor starter contactor closes, the motor starts running, and the yellow BOOSTER ON light comes on. The LOW GAS light will flash on and off until the outlet gas pressure switch makes. If it does not make within 15 seconds, the red LOW GAS light comes on steady and the alarm sounds.

To silence the alarm, press the ALARM SILENCE button.

## ALARM SILENCE



## SHUTDOWN

The booster can be stopped by:

- Opening the run interlock contact (appliance dedicated control mode)
- Turning the control switch to off
- Turning the main disconnect switch off

When shutting the system down to prevent operation, turn the main disconnect switch off and turn off the main power supply to the control panel.

# Maintenance & Troubleshooting

## 6

### MONTHLY CHECKLIST

- Inspect and tighten loose mechanical components
- Look for signs of damage and repair
- Test operation if the unit has not run and check for excessive vibration
- Clean the booster motor housing and cooling fan
- Wipe clean the control panel surfaces

### ANNUAL CHECKLIST

- Clean y-strainer screen
- Check inlet and outlet pressure switch settings
- Check and compare inlet and outlet pressures to the initial commissioning record sheet
- Measure and compare the power supply and motor current to the record sheet
- Perform operational test in the commissioning section of this guide

### TROUBLESHOOTING GUIDE

#### Alarm Conditions

Certain conditions will cause the ALARM to come on. To silence the alarm, press the ALARM SILENCE pushbutton.

- INLET LOW GAS MANUAL RESET PRESSURE SWITCH opens due to low utility line pressure. The LOW GAS light comes on and the booster motor will stop running. When the pressure is restored, this switch must be manually pushed to reset its contact.
- DISCHARGE GAS PRESSURE SWITCH fails to make within 15 seconds. The LOW GAS light comes on; the booster will not shut down.
- If the motor wiring or internal temperature switch opens, then the motor will stop causing the discharge gas pressure switch to open. Then the ALARM and LOW GAS light come on.
- A booster motor overload condition will shut down the booster and the MOTOR FAULT light and ALARM will come on.

## TROUBLESHOOTING PROCEDURES

PROBLEM	POSSIBLE CAUSE	SOLUTION
No POWER ON light	Main supply power is off	Be sure main power to the system is switched "on."
	Main disconnect switch is off	Turn the control panel main disconnect switch on.
	Loose connection	Check for voltage on panel terminals Turn off main power and inspect and tighten wire connections.
	Blown fuse	Verify that all fuses are good and properly installed. If blown, have a qualified electrician determine the cause and fix before replacing fuse.
Cannot initiate start sequence	Inlet low gas manual reset pressure switch has activated	Check incoming gas pressure; adjust if necessary.
		Check pressure switch setting and operation.
		If used, check that the pressure switch isolating valve is not closed.
	If used, Inlet High Gas Pressure Switch has activated	Normal operation, when the inlet pressure drops below the switch setting, then the system will start.
	Motor starter overload tripped	Check for defective motor, reset overload unit.
	Appliance interlock not made or jumper (continuous operation) is loose	Have qualified electrician verify and rewire.
Startup Sequence runs, but booster shuts down after several minutes.	Booster motor overload, thermal cut-out switch open	Verify voltage supply, booster motor rotation direction, sufficient inlet pressure, and that inlet/outlet valves are open. Let motor cool and reset overload.
Cannot achieve full capacity	Inlet/outlet piping too restricted	Rerun larger/straighter pipe runs.
	Inlet pressure too low	Consult with utility company.
	Booster motor rotation incorrect	Verify and have qualified electrician rewire.
	Manual inlet or outlet valve is partially closed	Open inlet/outlet valves fully.

# BOOSTPAK MODEL LS WIRING DIAGRAM

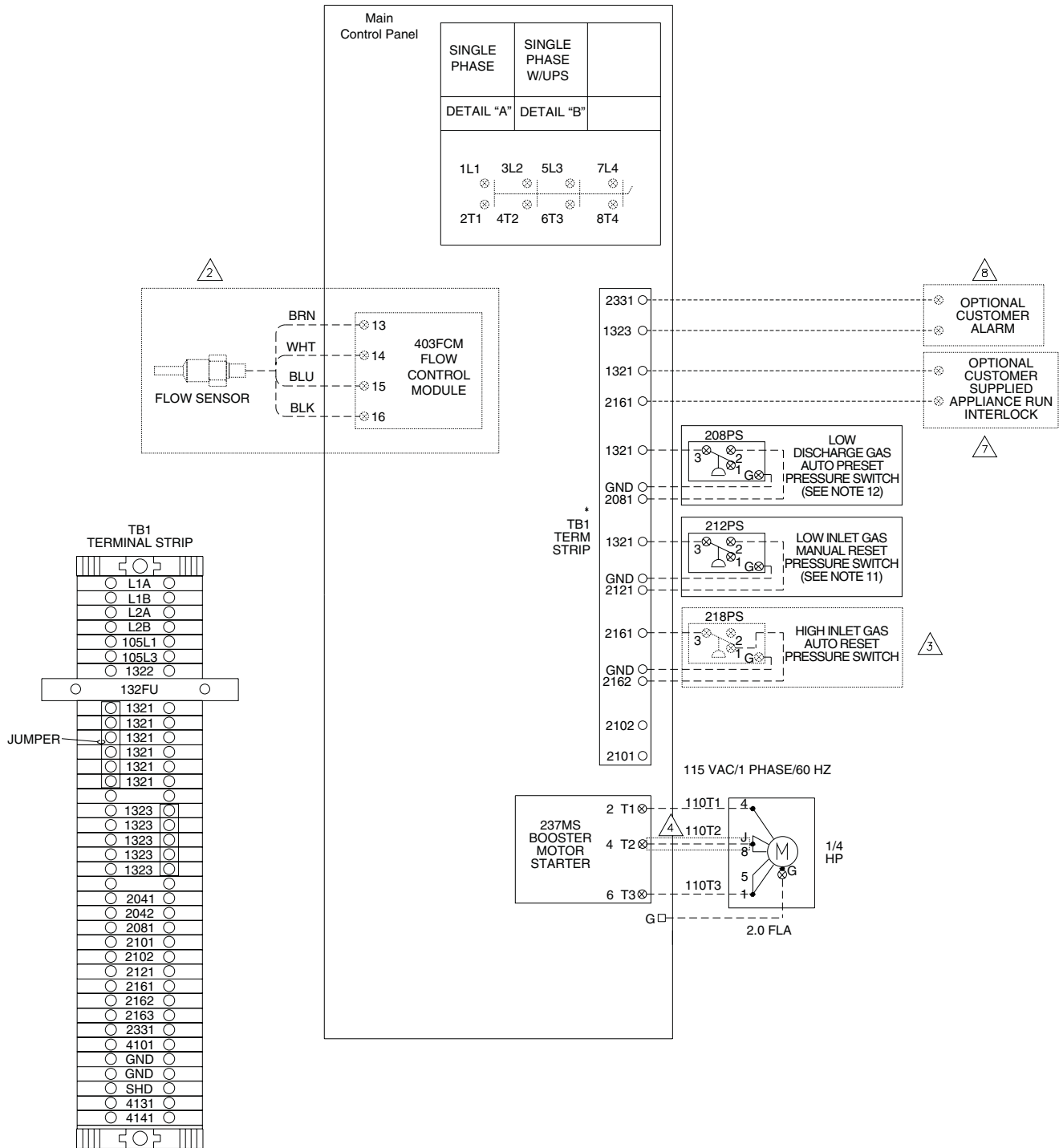

# BOOSTPAK MODEL LS WIRING DIAGRAM (CONTINUED)

DETAIL "A"  
SINGLE PHASE INCOMING POWER WITHOUT UPS OPTION

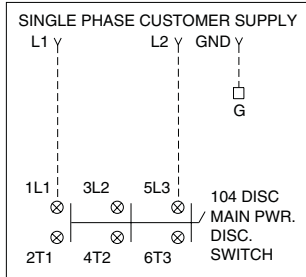

DETAIL "B"  
SINGLE PHASE INCOMING POWER WITH THE UPS OPTION

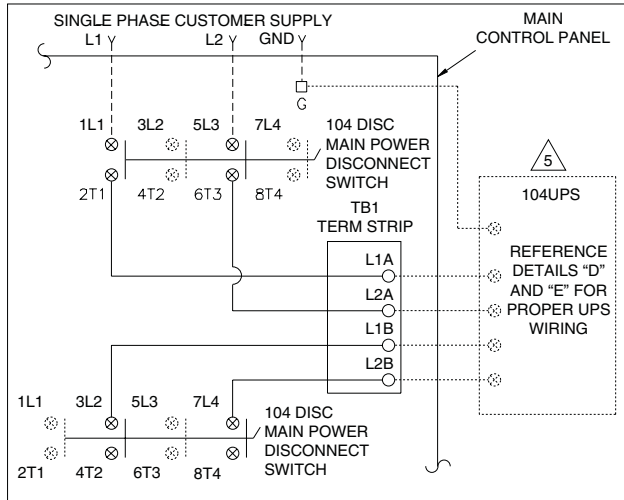

5

DETAIL "D"  
USED WHEN THE BOOSTPAK UNIT IS MOUNTED INSIDE & THE BOOSTER MOTOR IS 1/4 HP (LS MODELS)

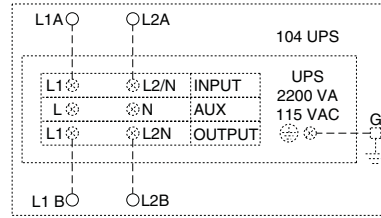

DETAIL "E"  
USED WHEN THE BOOSTPAK UNIT IS MOUNTED IN AN OUTDOOR LOCATION AND THE BOOSTER MOTOR IS 1/4 HP (LS MODELS)

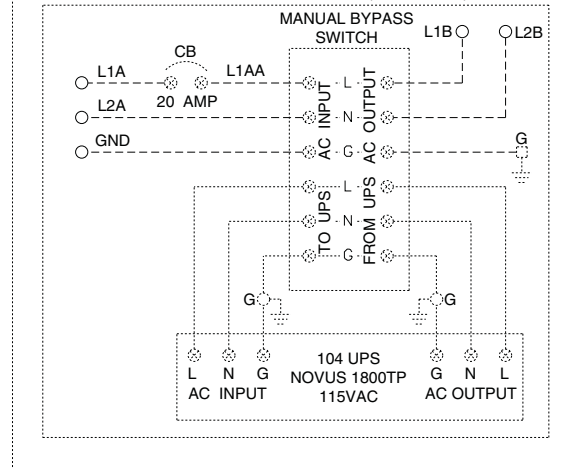

## NOTES

- 2 Phantom components marked 2 are installed on boostpak models with the flow control option. The flow control contact is set to close when gas fired equipment causes flow.
- 3 Phantom components marked 3 are installed on boostpak models with the high inlet gas pressure switch option. Set to value above which the downstream appliance can operate. Auto reset.
- 3 Phantom components marked 3 are installed on boostpak models with the UPS option.

- 7 Phantom component marked 7 is installed on boostpak models using the customer supplied appliance run interlock dry contact.
- 8 Phantom component marked 8 is the optional customer alarm. Maximum current is 2 amps.
- 10 All field wiring must conform to local electrical codes
- 11 Set at 3" W.C. or value by local utility company, breaks on pressure drop, manual reset.

- 12 Set @ 3" W.C. below rated boost pressure but not less than 2" W.C. Breaks on pressure drop, auto reset.

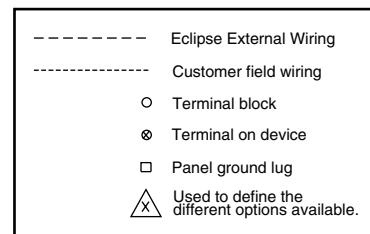



# BOOSTPAK MODEL LS PANEL LAYOUT

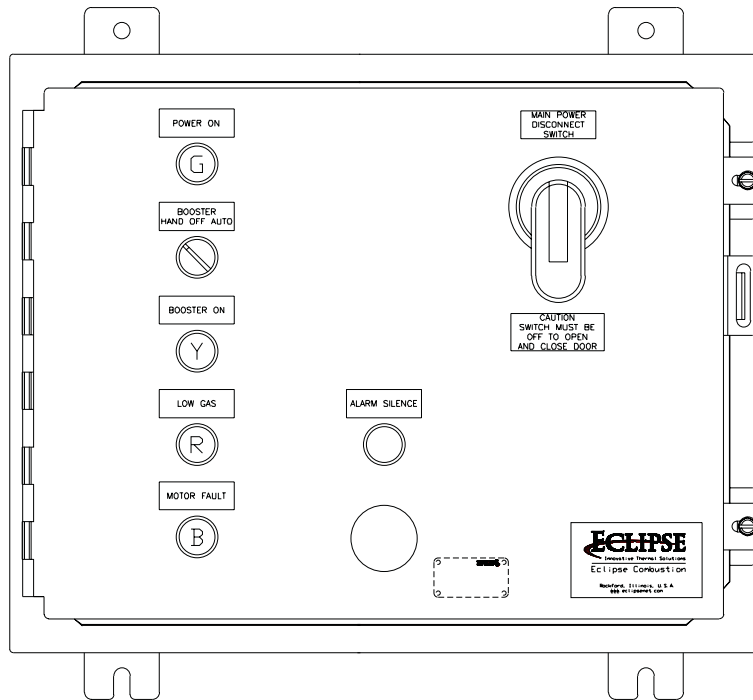

Enclosure 16"H x 20"W x 8"D

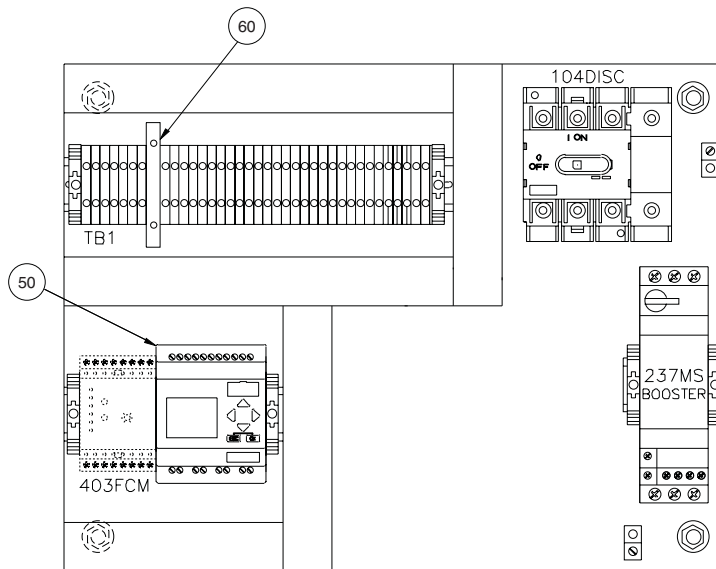











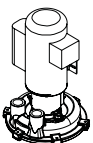

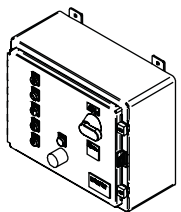

Internal View, Panel 13"H x 17"W

## BOOSTPAK MODEL LS SPARE PARTS LIST

Item Number	Eclipse Part Number	Description
10	14655	Inlet Pressure Gauge – 0-15" w.c. range
20	14955	Inlet Pressure Switch – Manual Reset, 1-20" w.c.
30	14658	Outlet Pressure Gauge – 0-35" w.c. range
40	14598	Outlet Pressure Switch – Auto Reset, 2-20" w.c.
50	10025036	PLC, program installed
60	10013758	Fuse, 5 amp

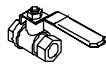

## KEY TO SYSTEM DRAWINGS

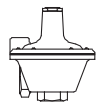
Symbol	Appearance	Name	Remarks	Bulletin/ Info Guide
		Hermetic Booster	Booster is used to increase gas pressure.	630-1
		Control Panel	The control panel encloses the booster motor starter, smart replay/PLC, disconnect and indicator lights for BoostPak operation.	630-1
		Check Valve	A check valve permits flow only in one direction and is used to prevent back flow of gas	780
		Pressure Switch	A switch activated by rise or fall in pressure. A manual reset version requires pushing a button to transfer the contacts when the pressure setpoint is satisfied.	Dungs 80110
		Pressure Gauge	A device to indicate pressure	940
		Gas Cock	Gas cocks are used to manually shut off the gas supply.	710
		Y Strainer	A y-strainer traps sediment to prevent blockage of sensitive components downstream.	
		Relief Regulator	A device to maintain a constant differential pressure between inlet and outlet.	



# Appendix

## CONVERSION FACTORS

### Metric to English.

FROM	To	MULTIPLY BY
cubic meter (m <sup>3</sup> )	cubic foot (ft <sup>3</sup> )	35.31
cubic meter/hour (m <sup>3</sup> /h)	cubic foot/hour (cfh)	35.31
degrees Celsius (°C)	degrees Fahrenheit (°F)	(°C × 1.8) + 32
kilogram (kg)	pound (lb)	2.205
kilowatt (kW)	Btu/hr	3414
meter (m)	foot (ft)	3.28
millibar (mbar)	inches water column ("wc)	0.401
millibar (mbar)	pounds/sq in (psi)	14.5 × 10 <sup>-3</sup>
millimeter (mm)	inch (in)	3.94 × 10 <sup>-2</sup>

### Metric to Metric.

FROM	To	MULTIPLY BY
kiloPascals (kPa)	millibar (mbar)	10
meter (m)	millimeter (mm)	1000
millibar (mbar)	kiloPascals (kPa)	0.1
millimeter (mm)	meter (m)	0.001

### English to Metric.

FROM	To	MULTIPLY BY
Btu/hr	kilowatt (kW)	0.293 × 10 <sup>-3</sup>
cubic foot (ft <sup>3</sup> )	cubic meter (m <sup>3</sup> )	2.832 × 10 <sup>-2</sup>
cubic foot/hour (cfh)	cubic meter/hour (m <sup>3</sup> /h)	2.832 × 10 <sup>-2</sup>
degrees Fahrenheit (°F)	degrees Celsius (°C)	(°F - 32) ÷ 1.8
foot (ft)	meter (m)	0.3048
inches (in)	millimeter (mm)	25.4
inches water column ("wc)	millibar (mbar)	2.49
pound (lb)	kilogram (kg)	0.454
pounds/sq in (psi)	millibar (mbar)	68.95



**Offered By:**

Power Equipment Company  
2011 Williamsburg Road  
Richmond, Virginia 23231  
Phone (804) 236-3800  
Fax (804) 236-3882

---

[www.peconet.com](http://www.peconet.com)